

HYDROGEN AND OXYGEN GENERATORS

OPERATING INSTRUCTION AND MAINTENANCE

GENERATOR

L/80

Data featured on the machine identification plate:

Machine model:

Serial number:

Year of manufacture:

Machine delivery date:

For assistance, contact the following centre:

ELETTRONICA TODESCATO Srl
36057 Arcugnano (Vicenza) Italia - Via A. Volta, 9/A-C
Tel. +39 - 444 289227 - Fax +39 - 444 289229
www.elettronicatodescato.com - e-mail: info@elettronicatodescato.com

INDEX
SECTION 1: Description and main features of the welder

1.1	Presentation	4
1.2	Warranty	4
1.2.1	Exclusion from warranty	5
1.3	Machine identification	5
1.4	Equipment	7
1.5	Machine description and use limitation	7
1.5.1	Description	7
1.5.2	Use limitation	7
1.6	Noise	8
1.7	Technical features	9

SECTION 2: Safety and prevention

2.1	Safety	10
2.1.1	General safety regulations	10
2.2	Safety signs (Symbols)	11
2.3	Safe use and maintenance	12

SECTION 3: Transport and installation

3.1	Packaging	13
3.2	Shipping	13
3.3	Unpackaging	13
3.4	Positioning	13
3.5	Storing	14

SECTION 4: Use

4.1	Connection to the electric circuit	14
4.2	Preparing the electrolyte	14
4.3	Tank filling	15
4.4	Booster tank filling	15
4.5	Preparing deoxidizer liquid	15
4.6	Hazardous operations	16
4.7	Starting the machine	16
4.8	Stopping the machine	17
4.9	Backfire	17
4.10	Safety device	18
4.11	Refilling deoxidizer liquid	18
4.12	Refilling distilled or demineralized water	18

SECTION 5: Maintenance

5.1	Generalities	19
5.2	Every six months	19
5.3	Once per year	19
5.4	Every four years	20
5.5	Putting the machine out of service	20
5.6	Scrapping	20
5.7	Disposing of the electrolyte	20
5.8	Disposing of the liquid deoxidizer	20
5.9	Trouble shooting	21
5.10	Interventions	25
5.10.1	What to do in order to see if the tank is short- circuit	25
5.10.2	Controlling pressure, adjustment valve	25
5.10.3	Checking valve tightness	26
5.10.4	Replacing the valve	26
5.10.5	Replacing the electrolyte	27

SECTION 6: Spare parts

6.1	Spare parts	27
-----	-------------	----

FIGURE LIST

Fig.1	Welding and components	6
Fig.2	Machine layout	9
Fig.3	Safety signs	12
Fig.4	Valve replacement	26
Fig.5	Spare parts	28
Fig.6	Wiring diagram	30
Fig.7	Gas circuit	31

SECTION 1

Description and main features of the welder

1.1 PRESENTATION

This manual gives information regarded as necessary to know, use correctly and carry out normal maintenance operations on this welder « **L/80** » (hereinafter referred to as machine) fabricated by «**Elettronica Todescato S.r.l.**» di Arcugnano (Vicenza) Italy (hereinafter referred to as Manufacturer).

The material in this manual is not intended to be a complete description of the parts nor a detailed explanation of their option. The user, however, will find the kind of information normally required to operate the machine correctly and safely and also to keep in good working condition.

Compliance with and observance of what is described in the manual is an essential condition for the trouble-free operation, long life and cost effective performance of the machine.



ATTENTION

Failure to observe the instructions in this manual, negligence, incorrect or improper use of the machine can be cause of machine warranty coverage cancellation by manufacturer. Manufacturer therefore declines any and all liability for injury to people or damage to property caused by failure to follow the instructions given in this manual.

Service work or overhauls involving complex operations must be entrusted to an authorized Technical Service Center which has the necessary specialized personnel, or directly to the Manufacturer who is at your complete disposal to ensure fast and complete technical assistance and anything else that can promote improved operation and optimal performance by the machine.



DANGER

This manual must be kept in a safe place at the disposal of the operator and service engineer, for consultation at any time during the machine's entire working life. It should be delivered with the machine if the latter is sold.

The manual must be kept in a safe place that is familiar to the assigned personnel. It is the responsibility of the personnel to keep the manual complete to allow for a consultation for the entire life of the machine. If the manual is damaged or lost, a copy must be immediately requested to the Manufacturer.

1.2 WARRANTY

Elettronica Todescato Srl ensures that the machine referred to in this manual has been tested in its own premises. The machine is guaranteed for 1 year (12 months) from the date of purchase. Should the machine be tampered with or improperly used, particularly concerning the safety devices, the warranty will be voided and the manufacturer will be discharged from any liability whatsoever.

Upon delivery, make sure that the machine has not suffered damage during transportation and that it is complete with all standard accessories and any optional equipment specifically ordered. Complaints must be written and submitted to your reseller within and not later than 8 (eight) days.

1.2.1 EXCLUSIONS FROM WARRANTY

This warranty shall be null and void (apart from the causes given in the Purchase Contract):

- If the machine is used with incorrect voltage.
- If the damage is due to insufficient maintenance or lack of proper service.
- If, following repairs carried out by the owner without manufacturers consent due to installation of non-original spare parts, the machine has been changed and the damage was caused by these changes.
- If the instructions given in this manual were not followed correctly.
- Exceptional events.

Damage caused by negligence, lack of care, improper and bad use of the machine or incorrect maneuvering by the operator shall also cause this warranty coverage to be null and void.



ATTENTION

Removal of safety devices installed on the machine will automatically make this warranty null and void of the Manufacturer.

1.3 MACHINE IDENTIFICATION

Each machine is equipped of identification plate (fig.1 # 21), giving the following information:

- Name and address of **Manufacturer**;
- «**CE**» mark;
- **A)** Machine type;
- **B)** Year of fabrication;
- **C)** Serial number;
- **D)** Voltage;
- **E)** Ampere;
- **F)** Watt;
- **G)** Frequency;
- **H)** Pressure.

The data given on the identification plate should be written in the spaces provided on the back cover of this manual and should always be specified when ordering spare parts or requesting Technical Assistance.

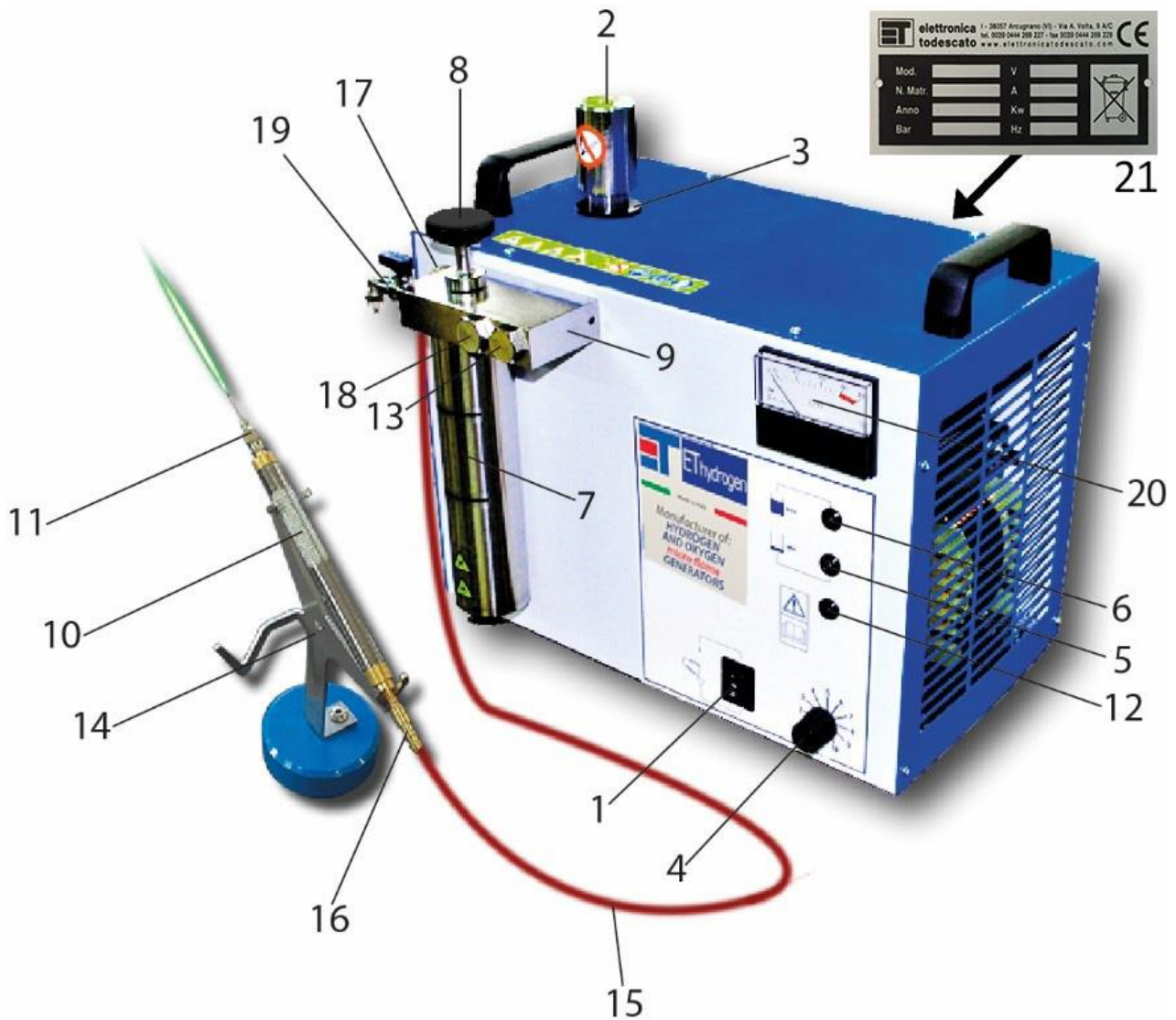

FIG. 1- WELDER AND COMPONENTS

Legend Fig.1

- | | |
|---|---------------------------------|
| 1. Three-position switch | 15. Torch hose |
| 2. Safety cap | 16. Torch hose fitting |
| 3. Filling neck | 17. Booster holder hose fitting |
| 4. Power control knob | 18. Back Flame Arrester Cap |
| 5. Minimum level indicator light (yellow) | 19. Shut off valve with fitting |
| 6. Maximum level indicator light (red) | 20. Gas Supply Indicator L/h |
| 7. Booster Tank | 21. Identification plate |
| 8. Handle knob | |
| 9. Booster holder | |
| 10. Torch | |
| 11. Burner tip | |
| 12. On indicator light (green) | |
| 13. Check valve cap | |
| 14. Torch holder (optional) | |

1.4 EQUIPMENT

Standard equipment

- Burner tip (Fig. 1 # 11).
- User manuals and DVD.
- Spare fuse (Fig. 5 # 37).
- Plastic funnel.
- Torch (es).
- Fire proof rubber hose.
- Power cord.

Optionals:

- Container with demineralized water.
- Container with liquid flux (deoxidizer).
- Torch holder (Fig. 1 # 14).
- 2.5 Bar pressure gauge.
- Electrolyte solution.
- One year maintenance kit.
- Igniter.

1.5 MACHINE DESCRIPTION AND USE LIMITATION

The «**ET- hydrogen L/80 Welder** is a machine marked with «**CE**» symbol in compliance with European Union regulations pursuant to EEC Directive 2014/35/UE and 2014/30/CE as detailed in the UE Declaration of Conformity annexed to each machine.

1.5.1 DESCRIPTION

The «**ET Hydrogen Welder L/80**» can be used in craftwork or industrial workshop with a minimum volume of 30 m³ and provided with natural ventilation by means of suitable openings to the outside in compliance with the regulations in force in the user's country. This machine is mainly used for soft and hard brazing applications in the fields of jewelry, goldsmith, costume jewelry, dental mechanics, micromechanics and for welding materials such as platinum, beryl, nickel, thermocouples, enamel copper, glass, quartz and for welding metal to metal and applicable for welding in industry, within the limitations of the machine.

1.5.2 USE LIMITATIONS

The hydrogen and oxygen mixture produced by this welder must be solely used to produce one flame for braze welding or thermal treatments of metal parts in general, or for working quartz glass.

**DANGER**

Any use different from those quoted here within and not included or not directly inferred from this instructions' manual, will be regarded as «NOT ALLOWED».

It is not permitted to operate the machine when the flame is out. This would result in an accumulation of explosive mixture in the surrounding environment and pollution caused by the methyl alcohol.

The machine has been designed for professional use. The operator must be of proven ability and capable of reading and understanding the instructions given in this manual. The operator must also use the machine in accordance with the ruling accident prevention standards, operating conditions and characteristics of the machine.

**DANGER**

THE USE OF THE MACHINE FOR ANY OTHER PURPOSE THAN THAT DESCRIBED IN THIS MANUAL RELIEVES THE MANUFACTURER OF ANY RESPONSIBILITY FOR DAMAGES TO PERSONS, ANIMALS OR THINGS RESULTING FROM INAPPROPRIATE USE.

1.6 NOISE

The noise level (acoustic pressure) was determined with the machine running under no load conditions with the readings of the 70 dB(A) inferior.

1.7 TECHNICAL FEATURES

FIG. 2– MACHINE LAYOUT

H₂/O₂ Gas production	lt/h	80
Water consumption	cc/h	50
Alcohol consumption	cc/h	12
Booster tank capacity	cc	153
Maximum power	Watt	500
Electrolyte	lt	1
Weight	Kg	25

SECTION 2

Safety and Prevention

2.1 SAFETY

The owner of the machine must instruct personnel about the risk of industrial accidents, the safety device installed for operator safety and on general industrial accident prevention regulations applied by law in the country where the machine is to be operated.

Operator safety is a matter of considerable importance for machine design and fabrication. When designing a new machine, every effort is made to foresee every possible dangerous situation and, naturally, adopt suitable safety devices to counter them. Therefore, a careful reading of this manual and special care and attention whenever any intrinsically operations have to be carried out are obligatory.



DANGER

Manufacturer declines any and all liability for injury to persons or damage to things caused by failure to follow this safety regulation and accident prevention recommendations detailed here.



Pay further attention when you see this symbol in the manual.

2.1.1 GENERAL SAFETY REGULATIONS



ATTENTION

Failing to comply with the information described in «Section 2 – Safety and Prevention» and the mishandling of the safety devices relieves the Manufacturer from any responsibility in the event of accidents, damage or machine malfunctions.

General rules:

- The user undertakes to entrust the machine to qualified and trained personnel only.
- The user is bound to take all the necessary measures for preventing unauthorized personnel from accessing the machine.
- The user undertakes to provide its personnel with adequate information regarding the application and observance of the safety regulations. To this end, the user undertakes to ensure that all the personnel understand the machine operating instructions and the safety regulations relative to their particular responsibility.

- The user must inform the Manufacturer of any defects or malfunctions in the accident prevention system and any situations of potential danger.
- The personnel must use personal protection items provided for by law and respect instructions given in this manual.
- The personnel must respect the danger and caution symbols on the machine.
- The personnel must not perform operations or interventions under their own initiative that lie outside their competence.
- The personnel is obliged to notify superiors of any problem or dangerous situation that may arise.
- The machine has been commissioned and tested with all the parts included within the standard equipment. The installation of parts or other makes or modifications to the machine may vary its characteristics and compromise its operating safety.
- The machine must only be used for the purpose for which it was constructed.

2.2 SAFETY SIGNS (Symbols)

During the construction of machine, all the possible solutions for the safety the operator have been adopted. The machine may nevertheless present ulterior risks which have not been possible to eliminate completely under certain operating conditions. These risks have been highlighted on the machine with adhesive warning symbols that indicate the various situations of reduced safety or danger.



ATTENTION

Keep the safety stickers clean and replace them immediately if they are peeling away or are damaged.

The following warnings refer to Figure 3. Read them carefully and learn their meaning.

- 1) **Excessive voltage. Before interventions, disconnect power.**
- 2) **Toxic substance, if swallowed. Do not inhale the vapors.**
- 3) **Easily flammable.**
- 4) **Corrosive liquid when in touch with body members.**
- 5) **Attention, electrostatic discharge sensitive device.**
- 6) **Flammable. Do not approach free flames.**
- 7) **Use protection glass.**
- 8) **Use protection mask for respiratory tract.**
- 9) **Use protection gloves.**
- 10) **Before using the machine, read the operating instructions carefully.**



FIG. 3 – SAFETY SIGNS

2.3 SAFE USE AND MAINTENANCE



ATTENTION

- The use of the machine is prohibited to:
 - o Operators who have not read and understood the instructions given in this manual;
 - o Inexperienced persons;
 - o Operators not in good physical/mental health.
- Periodically check that the machine and its protection devices are in perfect working order.
- Before maintenance operations or repairs on the machine, disconnect power.
- Maintenance operations and repairs must only be carried out by personnel trained to perform these special functions.
- At the end of the maintenance operations and repairs, before restarting the machine, the technical foreman must check that the work has been finished, the safety device reactivated and the protections reassembled.
- The spare parts must correspond with those stipulated by the Manufacturer. Only use original spare parts.
- During maintenance operations and repairs, protective clothing must be worn, i.e. protective eyewear, gloves for preventing cuts and mask for respiratory tract protection.
- Do not use water jets to clean the machine.

SECTION 3

Transport and Installation

3.1 PACKAGING

The welder is wrapped up in a polythene film and subsequently packed in a three-layer waterproof cardboard box sealed with adhesive tape and secured by a double strap.

3.2 SHIPPING

Whatever transportation method is used, either by plane, sea or land continental or intercontinental, the machine tanks will be empty.

IF REQUESTED OR WHERE PERMITTED:

The packaged electrolyte salts and/or bottled demineralized water, will be shipped according to the rules, law and regulations of the machine's destination (country).

3.3 UNPACKAGING

Make sure that:

- The welder has not suffered damage during transportation and, if necessary, report to the manufacturer or authorized reseller.

3.4 POSITIONING

Set the welder on a solid and stable surface, away from heat sources. Allow at least 50 cm of free space for the cooling louvres on the machine sides, for proper air circulation.

3.5 STORING

When the welder is in storage, the tank (Fig. 5 # 50) must be filled with electrolyte and the machine must be started for a few minutes at least once a month.

Avoid storing in humid places.

SECTION 4

Use

4.1 CONNECTION TO THE ELECTRIC CIRCUIT

Check that the main voltage corresponds to the voltage indicated on the plate at the rear of the welder (Fig. 1 # 21). Test the electrical circuit grounding to make sure that it is efficient.

- Slide the switch (Fig.1 # 1) to the "O" position.
- Insert power cord plug (Fig.5 # 31) into the current outlet.

4.2 PREPARING THE ELECTROLYTE

Pour **360 grams of KOH (Potassium Hydroxide)** into a clean stainless-steel vessel and/or hard plastic container that has been previously filled with 0,889 liters (0.234 US gal) of distilled or demineralized water. If the vessel needs to be cleaned, wash it with tap water a few times, until it becomes clean and after that, dry it with a rag. Stir immediately but gently, using a clean stainless-steel implement, until the product is fully dissolved, producing a reaction that generates heat. Wait until the solution has cooled down. **DO NOT USE DETERGENTS OR LIQUID SOAPS.**

DO NOT PREPARE the electrolyte solution inside the machine tank. It must be prepared into an external vessel **BEFORE** being introduced inside the machine tank.



DANGER

AVOID SPILLS. ALLOW COOLING TIME.

THE ELECTROLYTE IS HIGHLY CAUSTIC AND CAN CAUSE SERIOUS SCALDS TO THE SKIN AND HUMAN BODY. WHEN HANDLING THIS PRODUCT, ALWAYS MAKE SURE THAT A CONTAINER FULL OF WATER AND VINEGAR IS WITHIN REACH, IN ORDER TO BE ABLE TO WASH IMMEDIATELY ANY PART THAT COME INTO CONTACT WITH THE PRODUCT AND SUBSEQUENTLY RINSE CAREFULLY WITH RUNNING WATER.

THE USE OF PROTECTIVE CLOTHES, GLOVES, GLASSES, MASK FOR RESPIRATORY TRACT, IS OBLIGATORY.

IF THE PRODUCT COMES INTO CONTACT WITH THE EYES, WASH AND RINSE THEM REPEATEDLY AND IMMEDIATELY, THEN TAKE THE AFFECTED PERSON TO A FIRST AID STATION.

4.3 TANK FILLING

- 1) First of all, shut off all the flames, then slide the switch (Fig.1 # 1) to the “=” position; the green indicator light (Fig.1 # 12) and the “MIN” yellow indicator light (Fig.1 # 5) on the control panel will be illuminated.



- 2) **BEFORE ANY RE-FILL OPERATION, REMOVE THE BOOSTER TANK (FLUX) ALWAYS FIRST, (Fig 1 # 7).**
- 3) Remove the safety cap (Fig.1 # 2).
- 4) Through a funnel, pour slowly the electrolyte previously prepared through the filling neck (Fig.1 # 3) and into the tank (Fig.5 # 50). The “MAX” yellow light (Fig.1 # 5) will go out. If the “MAX” red light (Fig.1 # 6) does not shine after all the electrolyte has been poured into the tank, add distilled or demineralized water until the light is illuminated.



IT IS RECOMMENDED THAT NO WATER IS Poured WHEN THE RED LIGHT IS ON.

- 5) Put the safety cap back into place (Fig.1 # 2) and tighten it. Do not over tighten.
- 6) Slide the switch (Fig.1 # 1) to the “0” off position.

IMPORTANT NOTE:

For the first startup of our ET systems, or for the yearly maintenance (once every year), the machine must be filled or re-filled with electrolyte solution.

For the daily re-fill it is mandatory to pour only demineralized (or distilled) water inside the electrolyte tank.

Pouring daily electrolyte solution will cause a crystallization inside the tank and consequent obstructions of machine’s hoses, potentially causing a general malfunction.

4.4 BOOSTER FILLING

- 1) Loosen the handle knob (Fig.1 # 8) and remove the Booster Tank (Fig.1 # 7).
- 2) Pour the deoxidizer liquid (see sec. 4.5) into the Booster Tank until it reaches the “MAX” marked on the outside. Do not pour liquid beyond this level.
- 3) The eventual electrostatic charge of your body may cause **a spark and flame up the liquid deoxidizer**, this is to be avoided. Therefore take a moment to discharge your electrostatic charge on another metal object before approaching the Booster Tank. before approaching the Booster Tank while on its seat, you touch, for a moment with the other hand, the Booster holder (Fig.1 # 9). Repeat this operation each time you perform the Booster filling deoxidizer.
- 4) Place the Booster Tank back into place (Fig.1 # 7) and tighten the handle knob (Fig.1 # 8), just enough. Do not overtighten in order to preserve the gasket’s integrity.

4.5 PREPARING FLUX (DEOXIDIZER) LIQUID.



DANGER

METHYL ALCOHOL IS BOTH FLAMMABLE AND TOXIC. HANDLING MUST TAKE PLACE AWAY FROM FLAMES, SPARKS AND HEAT SOURCES. IN GENERAL AVOID CONTACT WITH THE MOUTH AND AVOID INHALING IT'S VAPORS.

By dissolving boric acid with methyl alcohol (as explained hereunder) you will obtain a green flame with high deoxidizing power, that is indispensable for braze welding operations, since it ensures optimal flow and penetration of the solder. In the thermic treatments, methyl alcohol is normally used in its pure state.

- 1) Pour the desired quantity of methyl alcohol into a plastic container provided with hermetic seal cap.
- 2) Add the boric acid in the form of flakes in a proportion of 15- 20 grams. (as a maximum) per each liter of methyl alcohol.
- 3) Close container, shake it up and wait until the product is fully dissolved, before using.

4.6 HAZARDOUS OPERATIONS



DANGER

When the flames are burning:

- **Do not unscrew the handle knob screw (Fig.1 # 8).**
- **Do not unscrew the Safety Cap (Fig.1 # 2).**
- **Do not bring flames or sparkles near the filling neck, safety cap, booster tank and booster holder (Fig.1 # 2, 3, 7, 9).**
- **Do not introduce metal objects inside the tank (Fig.5 # 50).**

4.7 STARTING THE MACHINE

- 1) Connect the welder to a current outlet.
- 2) Mount the burner tip onto the torch cone by screwing it and pushing it into place, until it is tight enough (Fig.1 # 11).
- 3) Set the power control knob (Fig.1 # 4) according to the indications shown in Table 2.
- 4) Slide the switch (Fig.1 # 1) to the “-“ position. The green indicator (Fig.1 # 12) and red indicator (Fig.1 # 6) will be illuminated.
- 5) Wait for approximately two minutes, until you hear/feel the emission of gas from the burner tip (Fig.1 # 11).
- 6) Light the torch with a standard lighter or an electronic igniter.

- 7) Clean the orifice (Fig. 1 # 11) with a thin steel wire or other similar safe object, in order to not cause personal harm or damage the burner tip. You may also put the burner tip in luke warm water for the cleaning of the orifice.



TORCH QTY	BURNER TIP EXTERNAL DIAMETER			Min	Lt/h	Max
1	Ø 0.6 mm/0.0236 inch		VIOLET	15		25
2	Ø 0.6 mm/0.0236 inch			30		50
1	Ø 0.7 mm/0.0275 inch		BLACK	20		45
2	Ø 0.7 mm/0.0275 inch			40		80
1	Ø 0.8 mm/0.0314 inch		GREEN	30		50
2	Ø 0.8 mm/0.0314 inch			60		80

TABLE 2

DANGER

You can adjust the flames by operating on the power control knob (Fig.1 # 4) which regulates the power and then consequently the flame. This should be set within the limit values presented, see TABLE 2. Setting the power level below the minimum value allowed would cause a pressure drop that would melt the burner tip, resulting in back fire in the Booster Tank.

4.8 STOPPING THE MACHINE

To turn off the welder, you must perform the following operations:

- 1) Put out the flame by rapidly pushing the base of the torch into a click motion. (Fig. 1 #16) (Fig. 1 #10).

DANGER

If this operation is performed slowly, it can result in backfire.

- 1) Slide the switch (Fig. 1 # 1) to the "0" (off) position.

ATTENTION

After turning off the machine and awaiting the necessary cooling time (approx. 5 hours), do not unscrew the safety cap. If this should happen, tighten it back and start the machine for 30 seconds, with the power control knob (Fig. 1 # 4) set on the maximum value.

**ATTENTION****4.9 BACKFIRE**

Backfire can occur for the following reasons:

- When putting the flame out, and the torch hose fitting is pushed too slowly, this operation should be done rapidly, as described above.
- The burner tip diameter is greater than the diameter recommended in TABLE 2.
- The gas delivery is insufficient, due to wrong power setting.
- Failure in the welder electric circuit.
- Lack of voltage in the supply channel.
- Insufficient amount of de-oxidizer or Booster Tank (Fig. 1 # 7) empty.
- Lack of gas in the supply channel.
- Obstructions or gas leakage.
- Backfire causes a faint detonation in the Booster Tank and if there is not deoxidizer, the flame will reach the Tank (Fig.5 # 50). To restart the welder you must perform those operations:
 - 1) Turn off the welder.
 - 2) Unscrew the safety cap (Fig. 1 # 2).
 - 3) Remove the flame arrester cap (Fig. 4 # 18) , replace the flame arrester (Fig. 4 # 51) and gaskets (Fig 4 52-54) replace the flame arrester cap (Fig 4 # 18) .
 - 4) Pour liquid deoxidizer into the Booster Tank until it reaches the required level; reassemble and start the welder. (see section 4.11)

4.10 SAFETY DEVICE

- **Safety cap:** **Safety cap:** it releases an excess of 2 Bar in overpressure.
- **Pressure switch:** cuts off the gas production when pressure exceeds 1.7 Bars.
- **Flame arrester:** stops the flame propagation in the tank and cuts off the gas supply.

4.11 REFILLING FLUX (DEOXIDIZER) LIQUID.

This operation must be performed after 6-8 working hours, when you see that the flame is fading and getting shorter, replace-it.

- 1) Put the flame out.
- 2) Turn off the welder.
- 3) Unscrew the handle knob (Fig. 1 # 8) and remove the Booster Tank.
- 4) Pour liquid deoxidizer into the Booster Tank until it reaches the maximum level marked on the outside.
- 5) Reassemble the Booster Tank and tighten the handle knob. Do not over tighten.

- 6) We suggest to refill the flux (deoxidizer) daily for optimal performance and better maintenance.

4.12 REFILLING DEMINERALIZED OR DISTILLED WATER



ATTENTION

When the machine uses up the water it must be refilled. This operation **MUST be performed when the yellow indication light is on (Fig. 1 # 5).**

- 1) Slide the switch (Fig. 1 # 1) to the “=” position.
- 2) With a clean funnel, slowly pour distilled or demineralized water through the filling neck (Fig. 1 # 3) until the red indicator light (Fig. 1 # 6) is illuminated. (Do not add more water than necessary). The generator autonomy of the operation is 6-8 hours when the tanks are full.
- 3) Tighten the safety cap (Fig. 1 # 2). Start the welder for at least 2 minutes or for all the time necessary.

SECTION 5

MAINTENANCE

5.1 GENERALITIES



ATTENTION

Any maintenance operation inside the welder must be performed solely by adequate technicians who have been officially trained.



DANGER

INSIDE THE MACHINE THERE ARE LIVE COMPONENTS (230 OR 115 VOLT AC), CONTACT WITH THESE PARTS CAN CAUSE ELECTRIC SHOCK.

5.2 EVERY SIX MONTHS

Disconnect the plug from the intake.

Remove the Booster Tank, the handle knob and the gaskets. Remove encrustations from the hole and the round groove underneath the Booster Holder.

We recommend to replace the booster gasket and the handle knob O. ring every six months. (Fig. 5 # 22, 24).

To clean eventual encrustations on the bottom of the Booster Tank and inside the torch proceed as follows:

- 1) Remove the liquid deoxidizer from the Booster Tank, soak it horizontally together with the torch in a container filled with about 6 cm of water.
- 2) Provide boiling for at least 30 minutes time necessary to complete dissolution of encrustations.

5.3 ONCE A YEAR

For optimal performance and safety measures it is necessary to replace the following parts:

- Check valve
- Electrolyte solution
- Torch fireproof rubber hose
- Gasket set
- Flame arrester

5.4 EVERY FOUR YEARS

Every four years the machine must undergo a complete technical and operational review. Such operation must be performed by the manufacturing firm or by skilled technical personnel.



ATTENTION

The manufacturing firm is not liable for any damage caused by the machine due to lack of review.

NOTE: The tank O-ring MUST be replaced every five (5) years according to the manufacture specification.

5.5 PUTTING THE MACHINE OUT OF SERVICE

- 1) Empty the electrolyte and rinse the tank.
- 2) Empty the liquid deoxidizer from the Booster Tank.
- 3) Disassemble the machine components and store them separately, according to the material they are made of.

5.6 SCRAPPING

Hand the materials that can be salvaged to companies specialized in recycling raw materials.

5.7 DISPOSING OF THE ELECTROLYTE

Neutralize it to PH7 by adding hydrochloric acid (and small part of albite in powder) and give disposition to an authorized company that handles toxic waste material.

5.8 DISPOSING DEOXIDIZER LIQUID

It can be regenerated by distillation. Alternatively, it must be handed over to a company specialized in the disposal of toxic products.

5.9 TROUBLE SHOOTING

We list hereunder the most frequent, operational complications, failures, relevant causes, and provide a brief description on how to repair or adjust the equipment in order to guarantee an adequate condition of the equipment in use that respects the manufacturers' parameters. Ensuring proper safety standards are abided by, maintaining functional performance, while keeping the integrity of the warranty guarantee established by the manufacturer.

MALFUNCTION	CAUSE	REMEDY
1) <i>The pointer of the gas supply indicator (Fig.1 #20) returns back to zero.</i>	<ul style="list-style-type: none"> - <i>The burner tip diameter is insufficient.</i> - <i>Obstructions due to scale formation</i> - <i>Backfire</i> 	<ul style="list-style-type: none"> - Change the burner tip - <i>See Table 2.</i> - Clean the apparatus (See sec. 5.2) - See sec. 4.9
2) <i>The flame is faint and elongated, its contours blurred. The flame heating power is insufficient.</i>	<ul style="list-style-type: none"> - <i>The electrolyte has been contaminated by foreign matter, such as methyl alcohol, oil, grease, etc...</i> 	<ul style="list-style-type: none"> - Replace the electrolyte (sec. 5.10.5). - Check the tightness of the valve (sec. 5.10.3). - Replace the check valve, if necessary (sec. 5.10.4).
3. <i>Flame is shortened and the reading of the gas supply indicator (Fig.1 # 20) is normal.</i>	<p><i>Obstructions due to scales or there is a gas leakage in the pneumatic channels (see par. 5.2).</i></p>	<p>Gas leakage: Do not depressurize the machine and remove the power cable.</p> <p>Start with a brush , spread soapy water all over the fitting and Booster Tank, below the Booster holder (17,7 and 9 Fig.5), on the torch hose fittings and torch cones (15,16 e 10 Fig.1). If you see bubbles coming up, it means that there is a gas leakage. Replace the safety cap if necessary.</p> <p>ATTENTION: The same operation</p>

		<p>can be performed on the fittings and hoses inside the welder. In this case, unplug the welder, for there are live components (230 or 115 Volts AC) inside.</p>
<p>4. The flame is shortened and the pointer of gas supply indicator (Fig. 1 # 20) doesn't rise normally</p>	<ul style="list-style-type: none"> - The electrolyte has been used up entirely or is contaminate with substances. - Electrolyte solution could be exhausted. (sec 5. 10. 5). - The power circuit board is faulty - Faulty 250 k rheostat - One of the two rectifier diodes (Fig. 5 # 27) is not conducting. 	<ul style="list-style-type: none"> - Change the electrolyte solution (see sec. 5.10.5). - Substitute the power circuit board (Fig.5, # 58) - Substitute the 250 k rheostat <p>How to spot the faulty diode: 1) Remove the cover (Fig. 5 # 32) from the frame. 2) Start the welder and let it work for 5-6 minutes with the flame off and the power control set at the maximum value. 3) Unplug the welder and touch immediately the body of the two rectifier diodes. 4) The temperature of the faulty diode is lower than that of the other diode.</p> <p>How to replace the faulty diode: Spread silicone grease all over the contacts surface of the new diode, mount it and tighten the stop nut underneath using dynamometric wrench set from 0,25 to 0,32 Kgm.</p>
<p>5. When starting the machine the fuse blows out. (Fig.5 # 37)</p>	<ul style="list-style-type: none"> - Power circuit board is short circuited - One of the rectifier diode is short-circuited. - Short-circuit inside the tank (Fig. 5 # 50), due to accidental introduction of a metal object. - Short-circuit of the tank cover (Fig. 5 # 46) with the tank, due to over compression of the cover "OR" (Fig.5#49). 	<ul style="list-style-type: none"> - Substitute the power circuit board <p>How to spot the short-circuited diode: 1) Disconnect the terminals of the two diodes (Fig. 5 # 27) from the copper flat conductors 2) Using an OHM meter (at OHM 1) measure the resistance between the body and the diode, nominal value of 600-2000 OHM. The defective diode, gives a very low value even if you invert the Ohm Meter points. 3) Replace the faulty diode.</p>
<p>6. No gas comes out of the burner tip</p>	<ul style="list-style-type: none"> - The power transformer (Fig. 5 # 40) is short-circuited. - The fan motor (Fig. 5 # 35) is short-circuited. - There is a leakage in the electric circuit. 	<ul style="list-style-type: none"> - Empty the tank (Fig. 5 # 50) and dry accordingly, verify that the anode in (Fig. 5 # 46) and that it is isolated from the cathode (Fig. 5 # 50). - Dismount the anode (Fig.# 5), and remove the metallic object causing the short circuit.

		<ul style="list-style-type: none"> - Verify that the O Ring in (Fig. 5, # 49) is mounted correctly and that the isolators (Fig 5 # 45) are inserted in such a way that the anode is not in contact with the cathode. - If the transformer is short-circuited, substitute the item. - Change the fan if needed - Verify that the internal cables are isolated or that there is no short-circuit , caused by the liquid consumed internally, if so, clean with demineralized water removing conductors or components damaged. - Substitute the diode making sure that special care is taken to put silicone on the surface of the new diode, tighten the diode with parameters of 0,25 – 0,32 Kgm
<p>Burner Tip (burns) and Back Flame occurs.</p> <p>8) The Flame appears Red or fluctuates</p>	<ul style="list-style-type: none"> - Flame is lit before the pressure arrives at the burner tip. - Burner tip excessively big whilst the the power regulator too low. - Turning machine off while leaving the flame mistakenly on. - Unscrew safety cap or booster tank while flame is lit. - Gas leakage in pneumatic channels. - <i>Flux (deoxidizer) is consumed</i> - <i>Liquid levels are above max limits</i> - <i>Humidity accumulation in the torch channel</i> - <i>Soapy substance internally formed , caused by contamination.</i> 	<ul style="list-style-type: none"> - Before opening flame, wait approx. 2 minutes to verify that the gas comes out of the burner tip. - Consult Table 2. - Always turn flame off before turning machine off. - Turn flame off, before removing booster tank or safety cap. - In case of gas leakage, repeat steps REMEDY 3 above. - substitute with new de-oxidizer - remove excessive liquids until reaching the proper indication - remove accumulated humidity, dismounting the torch and tubes, drying them. - Empty tank, repeat periodically with water then substitute the electrolyte solution.

TROUBLE SHOOTING FOR OVER PRESSURE

Possible reasons for over pressure Indicators

- 1) The power control knob is too tight for the selected needles (SEE TABLE 2)
- 2) A backfire has blocked the flame arrester or the check valve is blocked.
- 3) An obstruction of boric acid crystals has blocked the booster tank, the torches or the needles.

POSSIBLE SOLUTIONS:

Adjust the power control knob (FIG 1 # 4) or change the diameter of the needles as indicated in TABLE 2. of operating instruction manual.

- 1) Adjust the Power Control Knob (Fig 1 # 4) or change diameter of the needles as indicated in TABLE 2. of the user manual.
- 2) Replace the flame arrester or rinse the check valve with tap water or replace the check valve.
- 3) Immerse the booster tank, torches and needles in boiling water for a minimum of 30 minutes. before remounting all the parts, they must be dry.

GAS SUPPLY INDICATOR

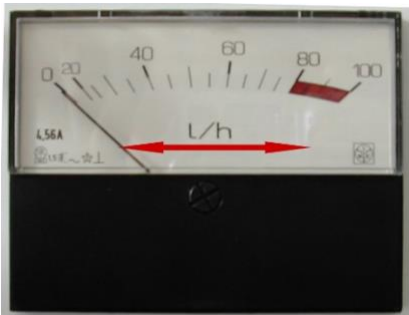

5.10 INTERVENTIONS

5.10.1 WHAT TO DO IN ORDER TO SEE IF THE TANK IS SHORT- CIRCUITED

- 1) Disconnect the plug from the correct outlet.
- 2) Remove the screws and remove the two copper conductors (Fig.5 # 59) from the tank cover (Fig. 5 # 46).
- 3) Turn on the machine.

If the fuse blows out: see Trouble Shooting sec. 5.9

If, on the contrary, the fuse does not blow out, perform the following operations:

- 1) Empty the electrolyte.
- 2) Disassemble the tank cover in the following order:
- 3) First remove the hose from fitting (Fig. 5 # 41), then the connectors of the two level sensors (Fig. 5 # 47, 48), paying special attention to the order of the connections, and the four nuts (Fig. 5 # 43).
- 4) Remove any metal object from the tank.
- 5) Replace the tank cover "OR" (Fig. 5 # 46), replace the cover insulators (Fig. 5 # 45) if faulty, center the tank cover and make sure that the "O-ring" (Fig. 5 # 49) is positioned properly in its seat.
- 6) Tighten the four nuts first manually and then by using a wrench, tighten uniformly and securely.
- 7) Connect the hose to the fitting, connect the level sensors and the two copper conductors.
- 8) Refill the tank with electrolyte.

5.10.2 CONTROLLING PRESSURE, ADJUSTING THE VALVE

- 1) Turn off the machine and remove the safety cap (Fig. 5 # 2).
- 2) Fit the pressure gauge on the filler neck (Fig. 1 # 3).
- 3) Unscrew the check valve cap (Fig. 1 # 13).
- 4) Turn the power control knob (Fig. 1 # 4), to the maximum power level.
- 5) Start the welder and wait until the pressure reading on the pressure gauge is stable.
Pressure should be 1.1 Bar.

ATTENTION:

It is very important that the valve is tight, since it enables the machine to maintain a minimum of approximately 0.3 Bar inside the tank, even after several hours.

Keep in mind that when the machine is not working, the tank cools down causing the pressure to drop.

If for some reason, there is a total lack pressure, the methyl alcohol contained in the Booster Tank would be sucked in, thus contaminating the electrolyte.

5.10.3 CHECKING VALVE TIGHTNESS

When the welder is on, the working pressure must be approximately, (1.0- 1.2 Bar). Then, after turning off the welder, check that the pressure reading on the pressure gauge drops to the approx. 0.5 bar, over 5-6 minutes. If the pressure drop is greater than 0.5 Bar, replace the valve (see. 5.10.4).



ATTENTION

It is very important that the valve is tight, since this enables the machine to maintain a minimum pressure of approx. 0.3 Bar inside the tank, even after several hours. Keep in mind that when the machine is not working, the tank cools down causing a pressure drop. If for some reason there is a total lack of pressure, the methyl alcohol contained in the Booster Tank would be sucked in, thus contaminating the electrolyte.

5.10.4 REPLACING THE VALVE

- 1) Turn off the welder and remove the pressure gauge or safety cap (Fig.5 # 2).
- 2) Unscrew the check valve cap (Fig. 4; A # 18).
- 3) Unscrew the threaded disk (Fig. 4; B # 21).
- 4) Remove the valve and relevant "O-ring" from the seat (Fig. 4; C # 23, 53).
- 5) Install the new valve (Fig.4; # 23).
- 6) Tighten the threaded disk (# 21), the cap (# 13), and safety cap (Fig.1 # 2).
- 7) Check pressure (sec. 5.10.3).

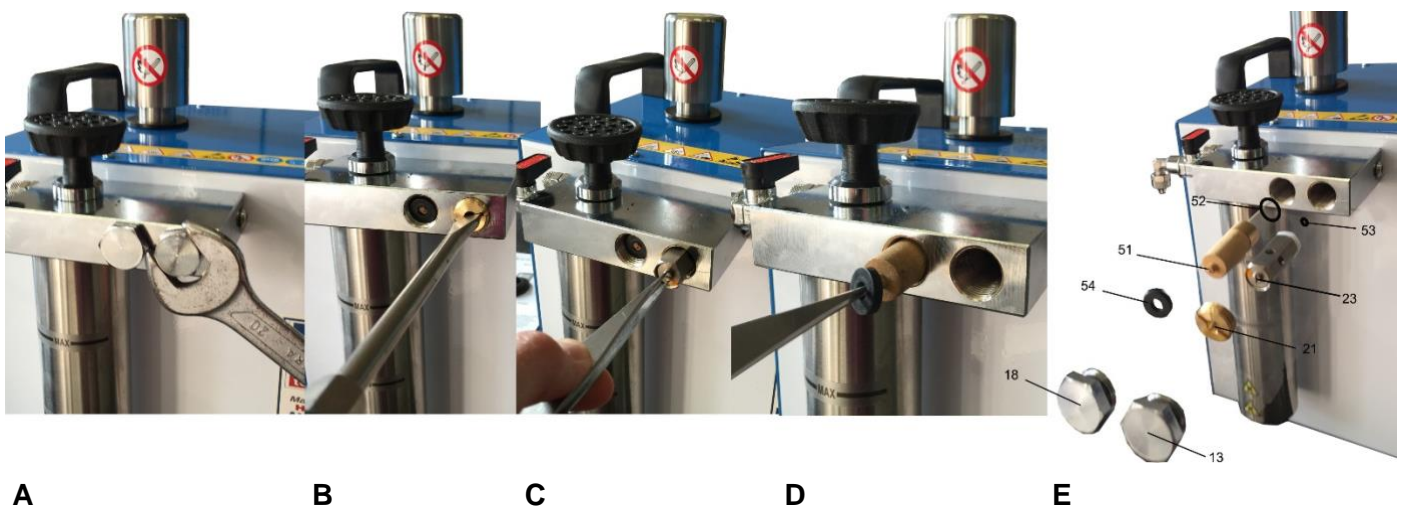

FIG 4 – CHECK VALVE AND BACK FLAME FILTER REPLACEMENT

5.10.5 REPLACING THE ELECTROLYTE

- 1) Empty the exhausted electrolyte.
- 2) Pour 0,890 Lt (0,235 US gal) demineralized water into the tank, shake well and empty.
- 3) Repeat this operation until the water that comes out is clean.
- 4) Pour the new electrolyte into the tank (sec. 4.2).

SECTION 6

SPARE PARTS

6.1 SPARE PARTS

Orders for spare parts should be sent to the Manufacturer or Authorized Distributor specifying the following information:

- **Machine Model.**
- **Serial Number.**
- **Year of Fabrication.**
- **Ordering Code Number** for the part required, description of the part and the number required.
- **Shipping Instructions.** If this is not specified by Manufacturer, even though doing its utmost to offer this service as efficiently as possible, cannot and it will not be liable for any shipping delays caused by force majeure events. Transportation costs are always to customer account. Goods travel at buyer peril and risk even if sold carriage forward.

Lastly, the Manufacturer is at your complete disposal for any technical assistance or spare parts needed.

SPARE PARTS Fig. 5

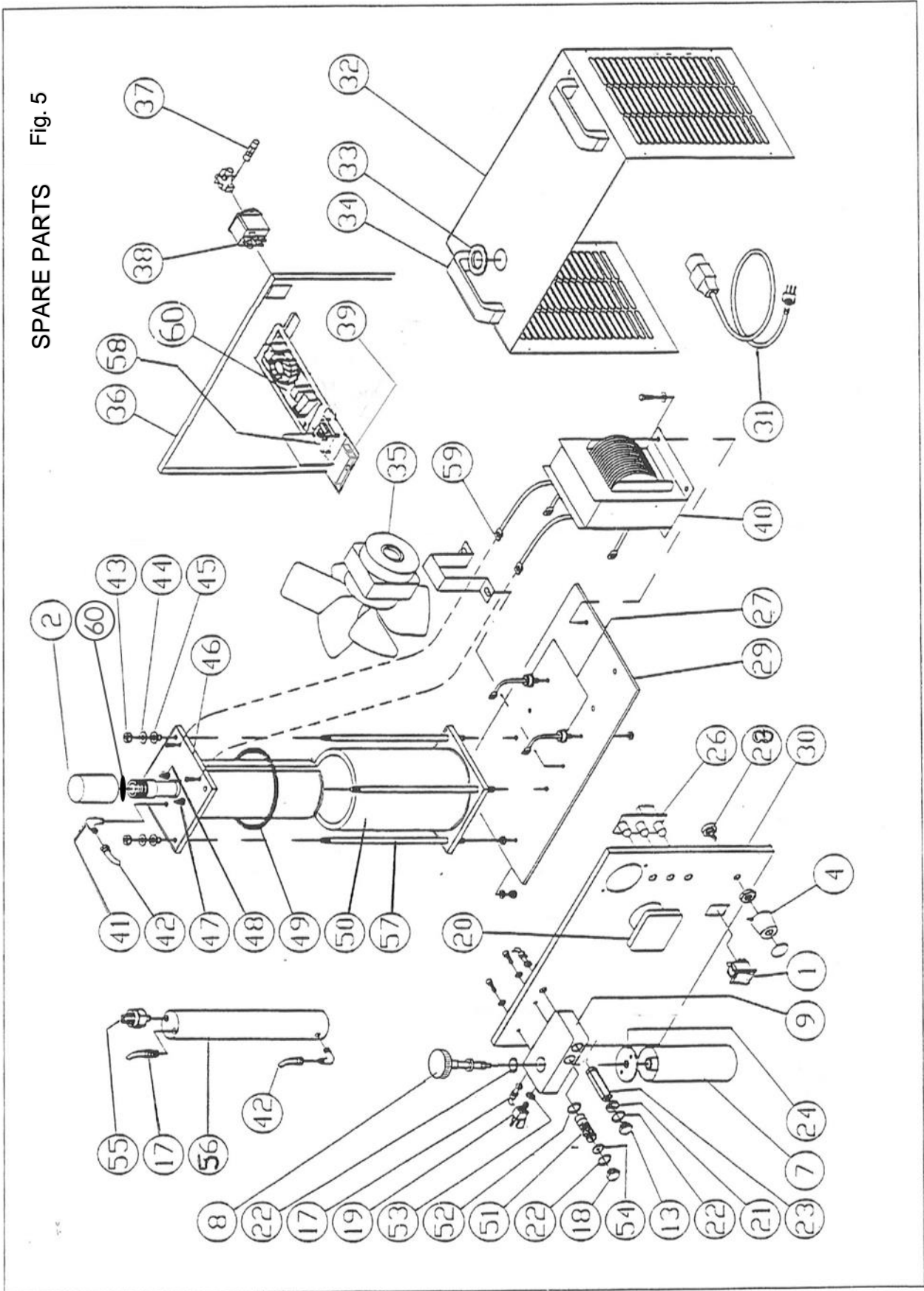

<i>Rif.</i>	<i>Cod.</i>	<i>Description</i>
1	1976	Three position switch
2	1200	Safety cap
3	-	See Fig. 1
4	1050	Power control knob
5	-	See Fig. 1
6	-	See Fig. 1
7	215	Booster Tank
8	540	Handle knob
9	496	Booster holder with 1/8" fitting
10	245	Torch (see table 1)
11	1-5-10-15	Burner tip diameter 0,6-0,7-0,8-0,9 mm
12	-	See Fig. 1
13	1195	Check valve cap
14	1118	Torch holder (see table 1)
15	1285	Torch hose 4x6 (see table 1)
16	-	See Fig. 1
17	2945	Fitting 1/8"
18	2606	Flame arresster cap
19	360	Shut off valve with fitting
20	2607	Gas Supply Indicator, L/h
21	1115	Threaded disk
22	730	Cap and handle knob O. Ring
23	1325	Check valve
24	556	Booster rubber gasket
26	141	Level circuit board
27	445	Rectifier diodes
28	811	250 k rheostat
29	445	Alluminium base plate
30	2609	Front panel
31	1930-75-1931	Power cord I-USA-D
32	1877	Cover
33	485	Rubber ring
34	645	Handle
35	680-690	Fan motor 230 V. – 115 V.
36	2608	Rear panel
37	1397	Fuse 8 A (230 V.) – 10 A (115 V.)
38	1111	Fuse holder plug + RFI Suppression filter
39	1085-1086	Resistor 3X10 k 230 V. – 2X10 k 115 V.
40	1230-1235	Power transformer 230 V. – 115 V.
41	2950	Fitting 1/8" 90°
42	1286	Plastic hose 4X6 mm
43	354	Nut 8 MA
44	117	Washer 8 mm
45	235	Insulator Ø 8 mm
46	85	Tank cover
47	1165	Minimum level sensor
48	1166	Maximum level sensor
49	750	Tank O.ring
50	285	Tank
51	493	Flame arrester
52	756	Flame arrester seat O.ring
54	737	Flame arrester gasket
55	940	Pressure switch
56	966	Separator
57	3411	Rod Ø 8 mm
58	985-986	Power control circuit board 115 V. – 230 V.
59	-	Copper conductors
60		Safety Tap Gasket

WIRING DIAGRAM Fig. 6

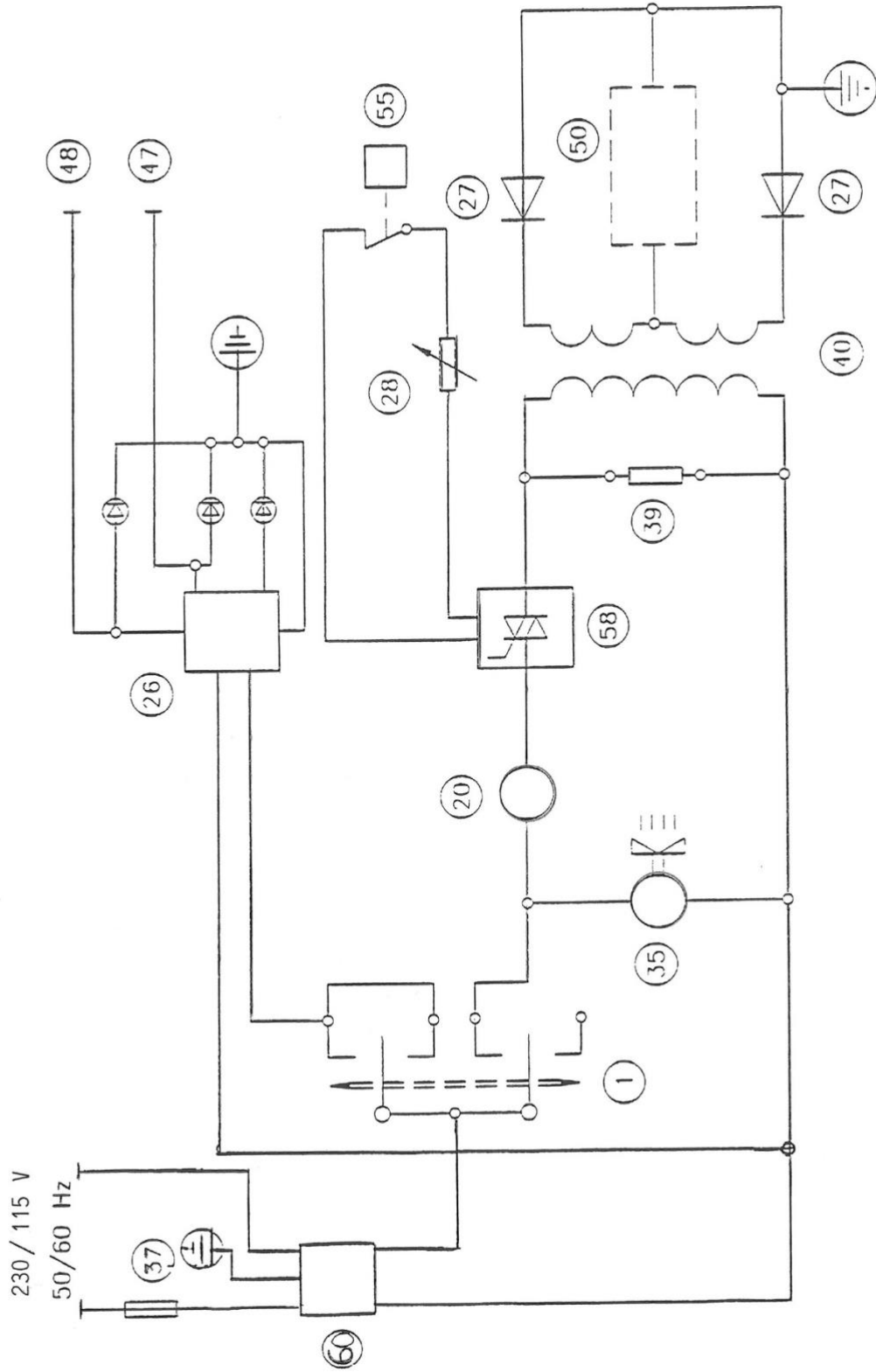
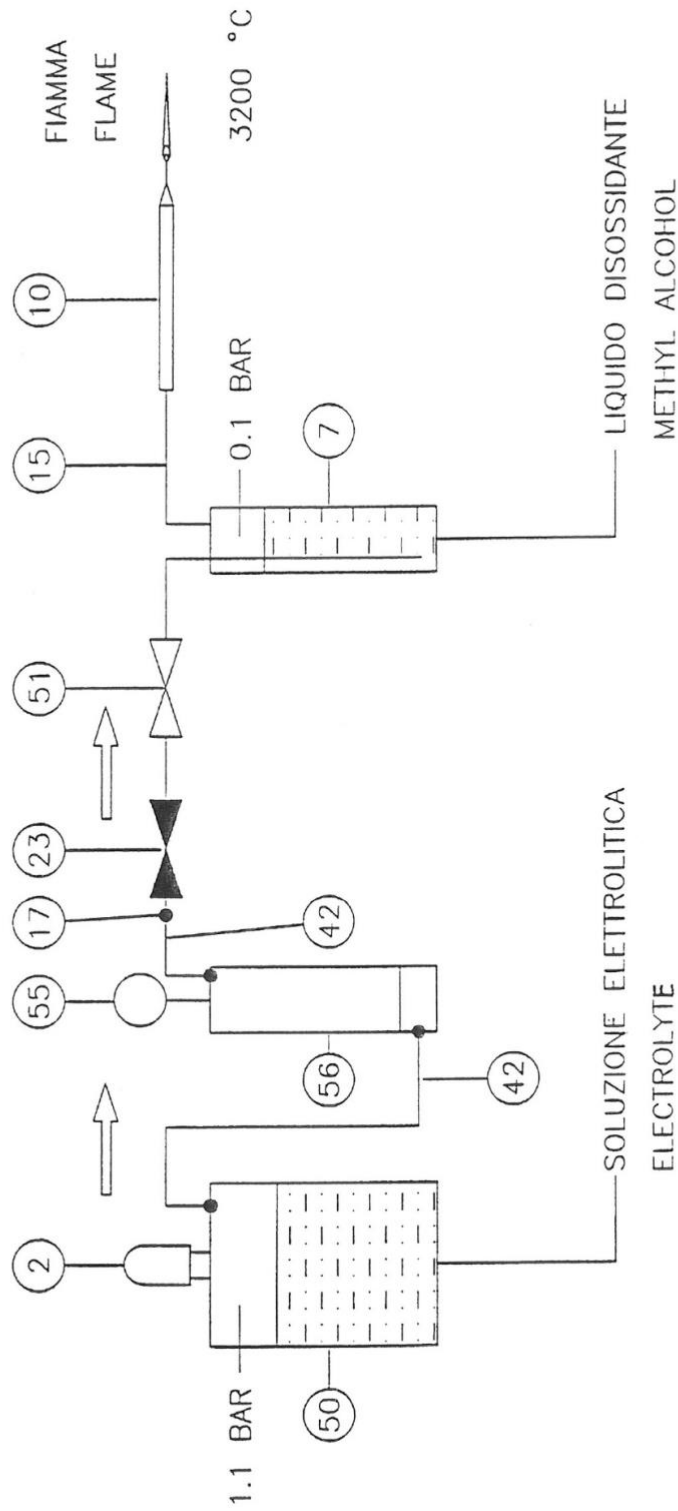

Fig. 7

GAS CIRCUIT





ELETTRONICA TODESCATO Srl

36057 Arcugnano (Vicenza) Italia - Via A. Volta, 9/A-C

Tel. +39 - 444 289227 - Fax +39 - 444 289229

www.elettronicatodescato.com – e-mail: info@elettronicatodescato.com